



Electrolux
PROFESSIONAL

Modular Cooking Range Line 900XP One Well Programmable Gas Fryer 23 liter, HP

ITEM # _____

MODEL # _____

NAME # _____

SIS # _____

AIA # _____



391343 (E9KKLBAMCG)

23-lt gas Fryer with 1 "V" shaped well (external heating elements), electronic control, programmable, oil recirculation pump, 2 half size baskets and lid included, automatic lifting system for baskets, automatic cooking function, prearranged for advanced filtering system

391379 (E9KKLQBAMCG)

23-lt gas Fryer with 1 "V" shaped well (external heating elements), electronic control, programmable, oil recirculation pump, 2 half size baskets and lid included, automatic lifting system for baskets, automatic cooking function, prearranged for advanced filtering system

Short Form Specification

Item No. _____

Burners in stainless steel. Suitable for natural gas or LPG attached to the outside of the well. Deep drawn V-Shaped well. The unit is equipped with a programmable electronic control panel. Automatic basket lifting system with automatic cooking mode. Unit predisposed for advanced filtering system. Melting function. Oil drains through a tap into a container positioned under the well; stainless steel filter included.

Height adjustable feet in stainless steel. Exterior panels in stainless steel. Worktop in 20/10, stainless steel. Right-angled side edges eliminate gaps and possible dirt traps between units.

Main Features

- High efficiency 26 kW burners in stainless steel with flame failure device attached to the outside of the well.
- Thermostatic regulation of oil temperature up to a maximum of 190 °C.
- Built-in smart electronic control system to monitor the temperature during frying to guarantee the safety of the process.
- The unit is predisposed for ADVANCED FILTERING SYSTEM with paper filters to remove the smallest food residuals and extend the oil life.
- Unit to feature automatic basket lifting system and AUTOMATIC COOKING mode.
- Unit able to memorize 5 programs (temperature and time) and 5 extra programs can be customized using the automatic cooking mode allowing to adjust the cooking time automatically according to the load.
- The special design of the control panel offers a better guarantee against oil infiltration.
- Flame failure device.
- Supplied as standard with 2 half size baskets and 1 right side door for cupboard and stainless steel sediment filter.
- Deep drawn V-Shaped well.
- Overheat protection thermostat as standard on all units.
- Integrated oil filtering system with a pump for oil circulation.
- All major compartments located in front of unit for ease of maintenance.
- Optional portable oil quality monitoring tool (code 9B8081) for efficient oil management.

Construction

- Interior of well with rounded corners for ease of cleaning.
- Unit is 930 mm deep to give a larger working surface area.
- All exterior panels in Stainless Steel with Scotch Brite finishing.
- Model has right-angled side edges to allow flush fitting joints between units, eliminating gaps and possible dirt traps.
- Unit delivered with four 50 mm legs in stainless steel as standard.

Sustainability



- This model is compliant with Swiss Energy Efficiency Ordinance (730.02).

APPROVAL: _____



Experience the Excellence
www.electroluxprofessional.com

Included Accessories

- 1 of Stainless steel oil filter for 23-litre fryer to remove particles of grease and food residuals) - 900XP PNC 200086
- 1 of Door for open base cupboard PNC 206350
- 1 of 2 half size baskets for 18/23 lt fryers PNC 927223

Optional Accessories

- Kit for advanced filtration system for 23-litre fryer, allowing to remove the smallest food residuals and extend oil life - 900XP PNC 200084
- Pack of paper filter (100 pieces) for advanced filtration system for 23-litre fryer - 900XP PNC 200085
- Stainless steel oil filter for 23-litre fryer to remove particles of grease and food residuals) - 900XP PNC 200086
- Kit for 23-litre fryer, drain extension in high resistant elastometer with stainless steel extremities to drain oil - 900XP PNC 200087
- Junction sealing kit PNC 206086
- Draught diverter, 120 mm diameter PNC 206126
- Matching ring for flue condenser, 120 mm diameter PNC 206127
- Kit 4 wheels - 2 swivelling with brake - it is mandatory to install Base support and wheels PNC 206135
- Flanged feet kit PNC 206136
- Support for bridge type installation, 1000mm (only for 391379) PNC 206138
- Pair of side kicking strips (not for refr-freezer base) PNC 206180
- Frontal kicking strip for 23lt fryers in two parts PNC 206203
- Extension pipe for oil drainage for fryers PNC 206209
- Flue condenser for 1/2 module, 120 mm diameter PNC 206310
- 2 drawers for open base cupboards, 100mm height (only for 391343) PNC 206334
- Door for open base cupboard PNC 206350
- Base support for feet or wheels (lateral) for 23lt fryers, pasta cookers and refrigerated bases (900XP) PNC 206372
- Kit G.25.3 (NI) gas nozzles for 900 fryers (only for 391343) PNC 206467
- 2 side covering panels for free standing appliances PNC 216134
- Sediment collection tray for 23-litre fryer (to be put in the well) PNC 921023
- 2 half size baskets for 18/23 lt fryers PNC 927223
- Pressure regulator for gas units PNC 927225
- 1 full size basket for 18/23 lt fryers PNC 927226
- Unclogging rod for 23lt fryers drainage pipe PNC 927227
- Deflector for floured products for 23lt fryers PNC 960645

Front

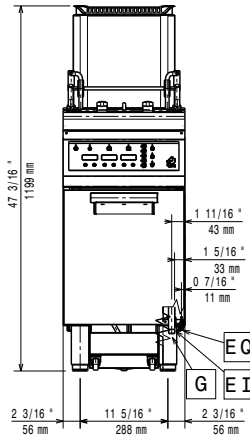

Side

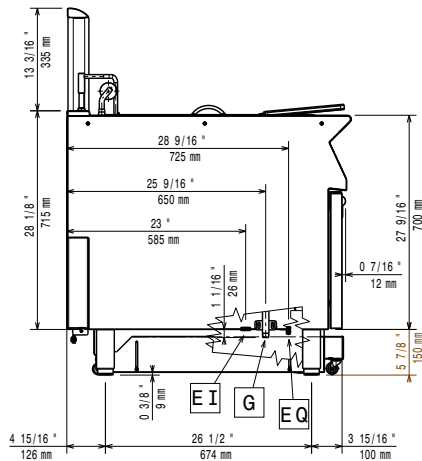

EI = Electrical inlet (power)
 EQ = Equipotential screw
 G = Gas connection

Top

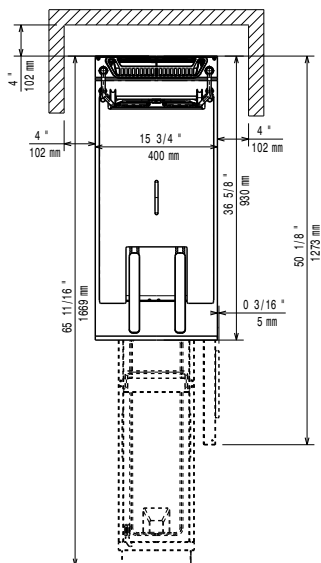

Electric

Frequency:

391343 (E9KKLBAMCG)	50Hz
391379 (E9KKLQBAMCG)	60Hz

Gas

Gas Power:	26 kW
Standard gas delivery:	Natural Gas G20 (20mbar)
Gas Type Option:	LPG; Natural Gas
Gas Inlet:	1/2"

Key Information:

Usable well dimensions (width):	340 mm
Usable well dimensions (height):	575 mm
Usable well dimensions (depth):	400 mm
Well capacity:	21 lt MIN; 23 lt MAX
Performance*:	36.5 kg\hr
Thermostat Range:	110 °C MIN; 190 °C MAX
Net weight:	96 kg
Shipping weight:	111 kg
Shipping height:	1480 mm
Shipping width:	460 mm
Shipping depth:	1020 mm
Shipping volume:	0.69 m ³

If appliance is set up or next to or against temperature sensitive furniture or similar, a safety gap of approximately 150 mm should be maintained or some form of heat insulation fitted.

*Based on: ASTM F1361-Deep fat fryers
 Certification group: GF91L23